

WACKER

CREATING TOMORROW'S SOLUTIONS

SILRES®

**CONCRETE PROTECTION
FOR CONCRETE ADVANTAGES**

COST SAVINGS AND ENVIRONMENTAL COMPATIBILITY THROUGH INNOVATIVE TECHNOLOGY



Contents

Prevention rather than renovation	2	Silane and silicone expertise from WACKER	12
Concrete: building material of the future	4	SILRES® BS Creme C	14
Concrete damage	5	SILRES® BS 1701	17
Concrete has two arch-enemies	6	SILRES® BS SMK 2101	18
Hydrophobic Impregnation	7	SILRES® BS 290	19
Long lasting protection	8	Preventive concrete protection	20
Silanes – stabilizer	9	Benefits at a glance	21
Silanes – reliable vehicle	10	WACKER services	22
Silanes – pioneers in water-repellent treatment	11	WACKER at a glance	23

Building Materials for New Dimensions

Concrete is today's main building material. Our age of globalization requires a stable and fully-functional infrastructure that connects people and markets. This infrastructure is based on concrete. Modern road and bridge construction would be inconceivable without concrete, as would skyscrapers and industrial buildings. Bigger, higher, wider – the global construction boom constantly sets new challenges for materials and technology, as the size and number of buildings increase. That's why concrete will remain the No. 1 building material in the future.

Concrete in Danger

Concrete is a versatile building material, used especially in civil engineering in combination with steel. However, concrete and steel are vulnerable to harmful substances that penetrate into the building material by means of moisture. This can result in costly concrete damage due to reinforcement corrosion.

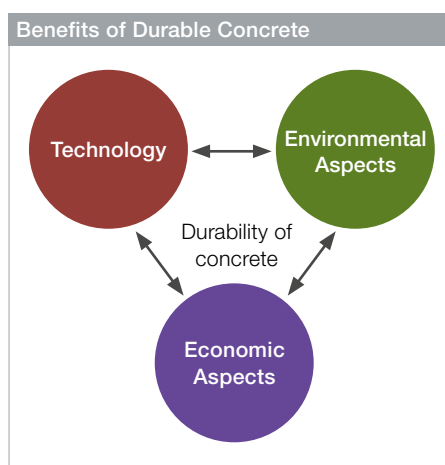

Concrete Needs Protection

Only effective preventive measures such as hydrophobic impregnation provide reliable protection for concrete structures. To this end, WACKER has developed environmentally compatible impregnating agents and highly effective techniques whose aim is to preserve the value of old and new buildings and protect them against weathering and structural damage.

Repair Is the Most Expensive Solution

Repairing concrete structures is up to ten times more expensive than preventive measures such as hydrophobic impregnation. With WACKER's innovative technology for the water-repellent treatment of concrete, it's possible to prevent repair – and so avoid high costs and consumption of energy and resources.

Hydrophobic Impregnation Reduces Costs by up to 90%

It's estimated that a water-repellent treatment costs only 10% of extensive renovations.

Cost Benefits for Property Developers

Specialists from Karlsruhe University, Germany, are convinced of the economic benefits of preventive measures and recommend surface protection of concrete structures. After all, the long-term cost savings for property developers are huge! Why is that? In fact the bulk of the costs – some 80% – are caused not by the actual repair work but by infrastructure measures (e.g. traffic diversions) and setting up the building site. In summary, we can see that **more prevention = fewer repairs = lower overall costs.**

CONCRETE WON'T BE OUTDATED ANYTIME SOON

Concrete and reinforced concrete are building materials that have significantly changed construction over recent years. Their development provided architects, builders and engineers with building materials that, in addition to offering excellent mechanical and physical properties (such as compressive and flexural strength), could be shaped in new and unprecedented ways. It became possible to erect imposing structures such as bridges, towers and skyscrapers, as well as more intricate structures. Its cost-effectiveness and durability also make concrete a vital building material for the future.

The Right Mix Is the Key

Concrete and reinforced concrete consist mainly of cement binder, sand aggregate and additives. In the case of reinforced concrete, the steel reinforcement improves the concrete's tensile strength. Water is also required – for hardening the cement and attaining the desired processing consistency. One way of determining concrete quality is by the water/cement value, the ratio of mixing water to cement. Excess water results in an increased number of capillary pores in the cement and thus a loss in rigidity. Correct processing and mixing of the ingredients is necessary to ensure a building material with excellent weathering and aging resistance. Otherwise, serious damage impends after a relatively short time.



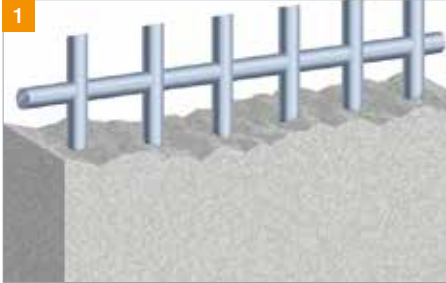

1 The reinforcement steel undergoes passivation in alkaline milieu.

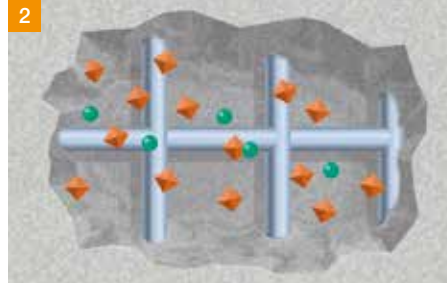

2 Dissolved salts, such as chlorides and acidic gases (e.g. CO₂), penetrate into the concrete and threaten the reinforcement.

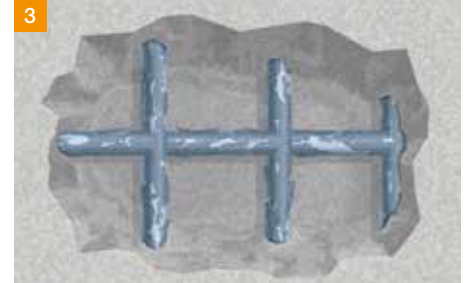

3 The salts reach the steel and dissolve the protective layer. Pitting corrosion starts to occur.

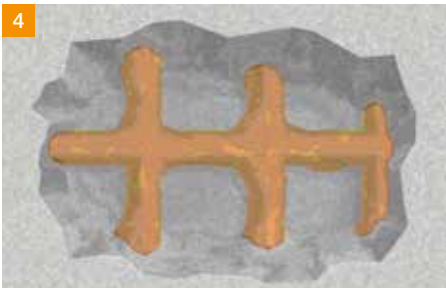

4 The corrosion process results in a volume expansion and pressure build-up in the structure.

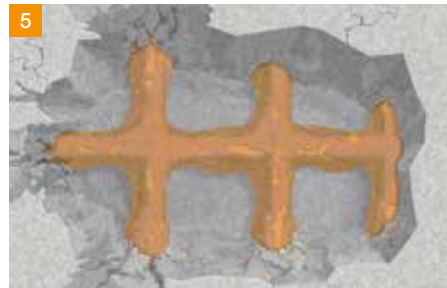

5 Crack formation and spalling of the concrete are the result.



6 The viewer sees the corrosion damages like that.

Despite concrete's durability, serious concrete damage that endangers a building's existence frequently occurs. The main cause of concrete damage is reinforcement steel corrosion due to environmental influences.

Chlorides Spoil the Cost Balance

Fresh concrete is highly alkaline, which passivates the reinforcement steel **1**. The greatest damage, which occurs, e.g., when the reinforcement steel corrodes, is caused by waterborne salts, particularly chloride ions. They are absorbed by the concrete, typically in the form of road salt or seawater). This particularly affects highway structures, but also buildings in coastal regions.

Corrosion Attacks Steel

Ultimately, the salt transported into the concrete by water **2** causes the steel's passivating layer (protective layer) to dissolve. Under the influence of oxygen and moisture, the steel begins to rust and pitting corrosion starts to occur **3**. Since the iron's corrosion process involves a drastic volume expansion (bursting force) **4**, the concrete layer above the reinforcement spalls **5**, resulting in serious concrete damage **6**.

CONCRETE HAS TWO ARCH-ENEMIES: WATER-SOLUBLE SALTS AND GASES



Its advantages, especially its cost efficiency, durability and scope for design, has made concrete today's most widely-used building material. Just a few years ago, many people still believed that concrete was resistant to every kind of harmful influence. However, concrete is not resistant to every kind of harmful influence and can be damaged.

Freeze/Thaw Cycles, Road Salts and Sea Salt Attack Concrete

Concrete damages always involve moisture. Although water is important in making concrete, it can also be destructive. Furthermore, it carries aggressive substances such as chloride ions from road salts into the concrete. Water is also a reaction medium and partner for destructive chemical processes that particularly attack the reinforcement steel by corrosion.

Concrete Absorbs Water

When concrete and other mineral building materials come into contact with water, they absorb an amount which depends on their porosity. This contributes to the following forms of damage:

Typical Structural Damage

- Concrete destruction by corrosion of the reinforcing steel (chloride induced)
- Chemical corrosion, e.g. binder transformation by acidic gases (SO_2 , NO_2 , CO_2)
- Cracks by swelling and shrinkage
- Frost damage and freeze/thaw damage by road salts
- Efflorescence and salt damage by hydration and crystallization
- Lime leaching
- Rust stains
- Dirt pick-up and stains
- Fungal, moss, lichen and algal growth

HYDROPHOBIC IMPREGNATION ENHANCES CONCRETE'S DURABILITY

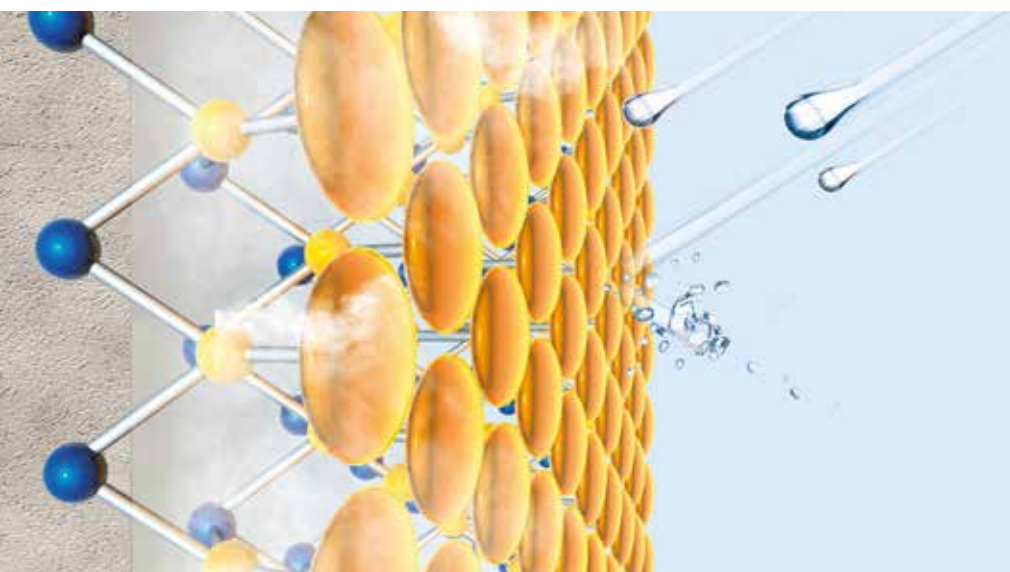

Much of the damage caused by moisture can be prevented, or at least reduced or kept at bay for longer, by means of hydrophobic impregnation.

Defense against Water and Harmful Substances

Absorption of harmful substances, which may lead to the structural damage described above, is usually the outcome of contact between the building material and water. This is an example of capillary water absorption, and also occurs when splashes of water land on de-icing salt. Forming a hydrophobic zone greatly reduces the amount of water and harmful substances which are absorbed. The building fabric remains drier as a result and is consequently less susceptible to the damage mechanisms described above.

Silanes Can Rescue Concrete Structures

The most efficient way of protecting concrete is to prevent water uptake. The past decades have shown that silanes with long alkyl chains (e.g. iso-octyl) are the ideal product class for this. Their current dominance in masonry protection stems from their outstanding water-repellency and durability. Silanes outperform rival product classes in their resistance to physical, chemical and microbiological attack. Provided that the right product is chosen, impregnation with silane will preserve a structure for a long time.

CONCRETE NEEDS EFFECTIVE AND LONG-LASTING PROTECTION

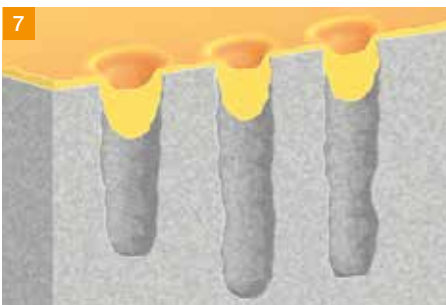
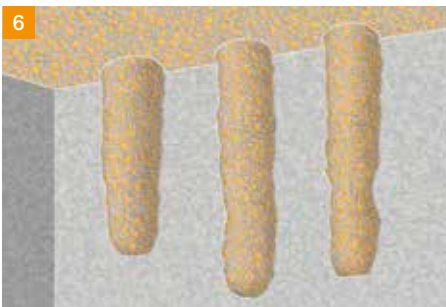

6 Water-repellent treatment – the capillaries remain open.

7 Film-forming coating – the capillaries are sealed.

WACKER has been working on developing and enhancing particularly long-lasting and cost-efficient concrete protection agents for over four decades. As hydrophobic impregnating agents, these target known sources of damage and fulfill the tough demands made on protective measures under difficult conditions.

The concrete's pores remain open after water-repellent treatment, so that water-vapor and gas diffusion are not measurably influenced. Thus, a concrete's natural properties are retained, and even when the surface is damaged (crack formation) it remains adequately protected. As a result, the water-repellent treatment has a significantly longer service life. These are clear advantages over film-forming coatings, which easily flake off as they don't allow water to pass out. Moreover, a damaged protective film quickly leads to concrete damage, as water and aggressive substances can then easily penetrate.

Modern Water Repellents Achieve:

- Drastic reduction in water uptake
- Chloride barrier and thus protection against reinforcement corrosion
- Retention of high water-vapor permeability
- Extensive penetration
- High UV resistance
- Surfaces not rendered shiny or tacky, or caused to yellow
- Adequate resistance to alkalis
- Safe use
- Exemplary environmental compatibility

Hydrophobizing and Film-Forming Measures

There are generally two methods available: hydrophobic Impregnation and film-forming coatings. In both cases, protection against moisture is central since water plays a key role by transporting corrosive substances, e.g. road salts, as well as facilitating the corrosion mechanisms.

SILANES – STABILIZER FOR CONCRETE STRUCTURES

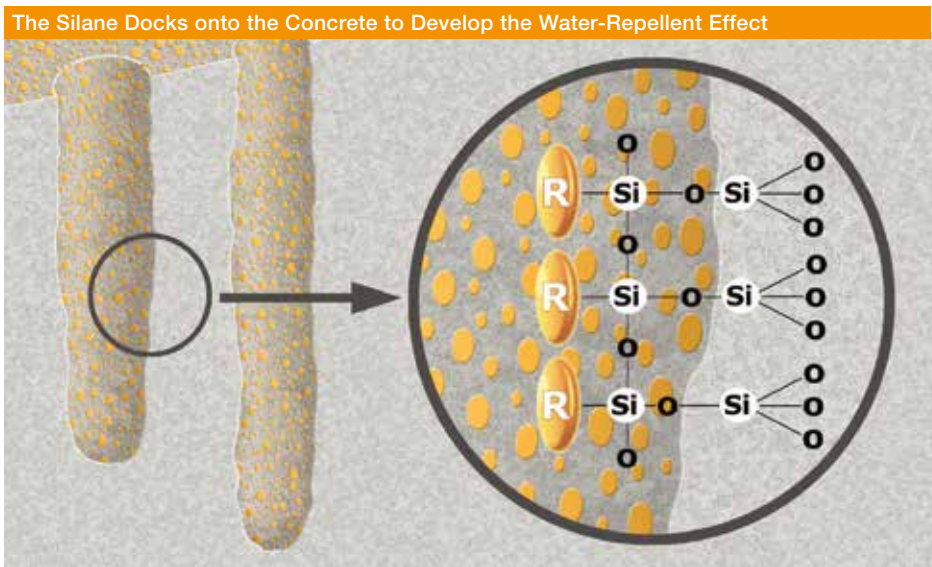

Silanes as Ideal Water-Repellent Agents

Organosilicon compounds have a long track record as water-repellent agents. They feature excellent water repellency without significantly impairing the water-vapor permeability, and long durability, which stems from silanes' high resistance to external influences such as UV radiation, thermal stress, aggressive substances and microbes. This is due to extremely stable covalent bonds between the silane and the silicate matrix of the pores and capillary walls in the concrete.

Silanes for water-repellent treatment of concrete must possess two specific properties: they must penetrate well into the relatively dense concrete and resist degradation by the high alkalinity found especially in fresh concrete. The purpose of hydrophobic impregnation is to protect exposed exterior walls from moisture and associated damage by applying a colorless, non-film-forming agent that prevents capillary uptake of water and the aggressive substances dissolved in it. Because the capillaries remain open, the substrate retains its vapor permeability.

Experts Confirm Benefits

Wacker Chemie AG is in constant contact with various research institutes, which describe this long-term effectiveness and significantly enhanced lifespan in many scientific papers.

SILANES – RELIABLE VEHICLES OF HYDROPHOBIC IMPREGNATION

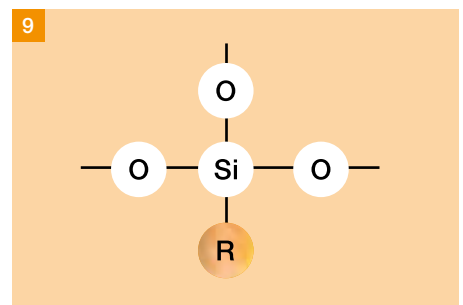
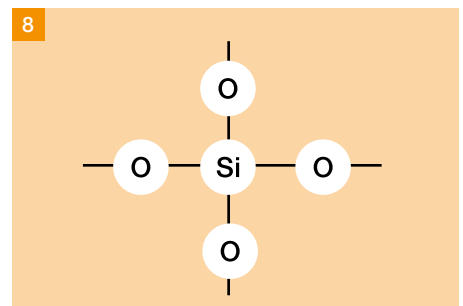

8 Quartz unit

9 Silane molecule

Fully-cured silane's close structural resemblance to quartz is the reason for its high affinity for silicate building materials, and for the exceptional durability of the hydrophobic impregnation.

Tried and Trusted

Organosilicon compounds have been recognized as the ideal active agents for the hydrophobic impregnation of absorbent mineral building materials for over 40 years now. The compounds work by binding strongly to the building material to form extremely stable Si-O-Si structures, similar to silicone resin. We can see the close similarity if we compare the molecular structure of a fully reacted silane **9** with that of natural quartz **8**. The fully reacted silane is simply a quartz modified with organic groups. This close structural resemblance is the reason for

the high affinity of silicone resins for silicate building materials, and for the exceptional durability of the water-repellent treatment. The organic group R makes the silane-treated construction material outstandingly water repellent. Since it is, moreover, extremely resistant to many chemical, physical and biological influences, the hydrophobic effect lasts for decades.

SILANES & SILOXANES PIONEERS IN HYDROPHOBIC IMPREGNATION



Today, alkylalkoxysilanes such as iso-octyltriethoxysilane set the standard in terms of highly efficient penetration and excellent resistance to high alkalinity. They are colorless, low-molecular (and thus low-viscosity), highly penetrating liquids that are generally applied to concrete in undiluted form. There, they react with moisture, liberating alcohol, and form extremely stable bonds with the pores and capillary

walls of the concrete. After the reaction, the iso-octyl group juts out into the centre of the capillaries and pores, which is the reason behind hydrophobic impregnation's high effectiveness.

Optimum Silane Efficiency

Today's scientific findings confirm silanes' excellent and long-lasting effectiveness as concrete water repellents. However, for optimum effect, two points must be observed during processing:

- Liquid water repellents must generally be applied in several coats to achieve the required active concentration and penetration depth;
- On vertical and particularly overhead surfaces, the material could potentially run off before it penetrates into the concrete. In such cases, products with higher viscosity such as SILRES® BS Creme C are ideal for attaining an adequate contact time. More details on page 14.

WACKER CHEMIE AG – THE SILANE AND SILICONE EXPERT IN MASONRY PROTECTION



Wacker Chemie AG has been a leader in masonry protection with silicones for decades. Its broad series of masonry protection agents covers an extensive range of applications, from preservation of historic buildings to concrete protection. Ongoing product development ensures that products are continually adapted to meet market requirements.

Allow us to introduce our proven and reliable products for concrete protection, with which you can protect your building against moisture and associated further damage:

Products

SILRES® BS Creme C – the expert

SILRES® BS 1701 – the generalist

SILRES® BS SMK 2101 – the specialist

SILRES® BS 290 – the all-rounder



SILRES® BS Creme C – the Expert

- Certified to EN 1504-2
- Water-repellent cream
- Aqueous
- Solvent-free
- Silane-based
- For concrete and reinforced concrete
- Use undiluted

SILRES® BS 1701 – the Generalist

- Certified to EN 1504-2
- Liquid water repellent
- Monomeric silane
- For concrete and reinforced concrete
- Use undiluted

SILRES® BS SMK 2101 – the Specialist

- Certified to EN 1504-2
- Solvent-free silicone microemulsion concentrate
- Silane/siloxane-based
- Impregnating agent for concrete and reinforced concrete
- Impregnating agent for in-plant-manufactured building materials
- Use diluted in water

SILRES® BS 290 – the All-Rounder

- Liquid general-purpose water repellent
- Liquid general-purpose primer
- Solvent-free silane/siloxane mixture
- For mineral and alkaline substrates
- Use diluted in solvent

SILRES® BS CREME C – THE EXPERT IN HYDROPHOBIC IMPREGNATION OF CONCRETE



Responsible Care® is a global, voluntary chemical-industry initiative. Its aim is to make tangible contributions toward sustainable development.

WACKER Products are Certified Products



Certified to
EN 1504-2

SILRES® BS Creme C is an aqueous, solvent-free, water-repellent cream based on silane. It's a high-quality specialty product for the hydrophobic impregnation of concrete and reinforced concrete.

The Formula for Deep-Pore Protection

SILRES® BS Creme C is characterized by:

- Excellent penetration
- Being solvent-free, aqueous and environmentally compatible
- Low volatility
- Optimum resistance to alkalis

The treated concrete exhibits the following lasting properties:

- Drastic reduction in chloride and water absorption
- Retention of breathability by the substrate
- High protection against freeze/thaw
- Good paint adhesion

SILRES® BS Creme C's thixotropic consistency is unique among water repellents and its properties are excellent for the hydrophobic impregnation of high-quality concrete and reinforced concrete. Unlike conventional liquid products, SILRES® BS Creme C can be applied to the required extent in just one or sometimes two steps. Depending on porosity and thus concrete quality, the silane active ingredient penetrates into the substrate within a short period of time (30 minutes to a couple of hours) and there it reacts, liberating alcohol with the silicate matrix of the capillaries and pores of the concrete. The creamy layer that was initially white disappears completely. Since the active ingredient is the same as in conventional liquid water repellents, water-repellent treatment with SILRES® BS Creme C also allows the pores and capillaries of the substrate to remain open, leaving the substrate breathable.

SILRES® BS Creme C is designed so that the active ingredient penetrates as deeply into the concrete as possible and thus optimally protects against the absorption of water and aggressive substances, as well as against damage from freeze/thaw.

Applications

SILRES® BS Creme C is particularly recommended for the hydrophobic impregnation and priming of concrete and reinforced concrete in road, bridge and building construction. In general, SILRES® BS Creme C is suitable for all alkaline substrates that were conventionally treated with concentrated or undiluted water repellents such as alkoxy silanes.

Comments

Comprehensive instructions are given in the appropriate material safety data sheets. These are available from our sales subsidiaries or can be printed from WACKER's website www.wacker.com.



10 Freshly applied SILRES® BS Creme C.

11 30 minutes after application.

12 Two hours after application.

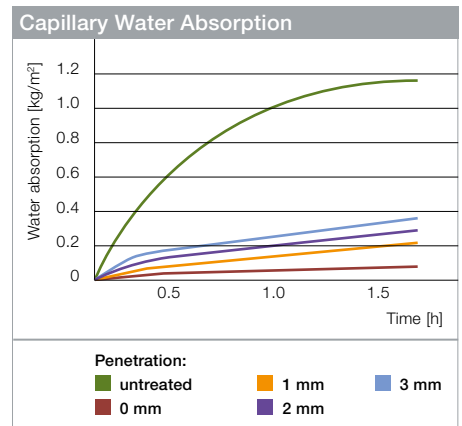

Capillary water uptake of drill cores taken from the Fürstenland bridge in St. Gallen, Switzerland, at varying depths (1-mm thick slices are cut off and inspected). Source: LPM report 17'160-2 of May 28, 1997



SILRES® BS 1701 – THE UNIVERSAL SILANE



Responsible Care® is a global, voluntary chemical-industry initiative. Its aim is to make tangible contributions toward sustainable development.

WACKER Products are Certified Products



Certified to
EN 1504-2

SILRES® BS 1701 is a mixture of isomeric octyltriethoxysilanes with iso-octyltriethoxysilane as the main component. SILRES® BS 1701 is used in undiluted form for the hydrophobic priming and impregnation of concrete and reinforced concrete.

Special Features

SILRES® BS 1701 is characterized by:

- Excellent penetration
- Being solvent-free and environmentally compatible
- Low volatility
- Optimum resistance to alkalis

The treated concrete has the following lasting properties:

- Drastic reduction in chloride and water absorption
- Retention of breathability
- High protection against freeze/thaw
- Good paint adhesion

After application to the concrete, SILRES® BS 1701 reacts initially with atmospheric moisture or the building material's pore water. In the zone where the impregnating agent has penetrated, the active agent formed greatly reduces the concrete's absorption, but without blocking the concrete's pores and capillaries. The impregnated building material retains its very high water-vapor permeability.

Applications

SILRES® BS 1701 is recommended for the hydrophobic impregnation and priming of concrete and reinforced concrete in road, bridge and building construction.

Comments

Comprehensive instructions are given in the appropriate material safety data sheets. These are available from our sales subsidiaries or can be printed from WACKER's website www.wacker.com.

SPECIALTY

SILRES® BS SMK 2101



Responsible Care® is a global, voluntary chemical-industry initiative. Its aim is to make tangible contributions toward sustainable development.

SILRES® BS SMK 2101 is a water-dilutable, solvent-free silicone micro-emulsion concentrate based on a silane/siloxane mixture. Diluted in water, SILRES® BS SMK 2101 is a high-quality specialty product for the hydrophobic impregnation and priming of concrete and reinforced concrete.

Special Features

SILRES® BS SMK 2101 is characterized by:

- Proven penetration into the concrete
- Low volatility with low evaporation losses during application
- Dilutable with water; no solvent content
- High resistance to alkalis

The treated concrete has the following lasting properties:

- Drastic reduction in water and chloride absorption

After application to the concrete, SILRES® BS SMK 2101 reacts. In the zone where the impregnating agent has penetrated, the active agent formed greatly reduces the concrete's absorption, but without blocking the concrete's pores and capillaries. The impregnated building material retains very high water-vapor permeability.

Applications

SILRES® BS SMK 2101 is recommended for the hydrophobic impregnation and priming of concrete and reinforced concrete in road, bridge and building construction.

Comments

Comprehensive instructions are given in the appropriate material safety data sheets. These are available from our sales subsidiaries or can be printed from WACKER's website www.wacker.com.

WACKER Products are Certified Products



Certified to
EN 1504-2

GENERAL-PURPOSE

SILRES® BS 290



Responsible Care® is a global, voluntary chemical-industry initiative. Its aim is to make tangible contributions toward sustainable development.

SILRES® BS 290 is a solvent-free silicone concentrate based on a silane/siloxane mixture and can be diluted with organic solvent. Diluted in this way, SILRES® BS 290 is a high-quality general-purpose impregnating and priming agent for mineral and strongly alkaline substrates.

Special Features

SILRES® BS 290 is characterized by:

- Good penetration
- Rapid drying, with no tackiness
- Effectiveness even on damp building materials
- High resistance to alkalis

The treated concrete has the following lasting properties:

- Drastic reduction in chloride and water absorption

After application to the concrete, SILRES® BS 290 reacts with the atmospheric moisture or the building material's pore water. In the zone where the impregnating agent has penetrated, the active agent formed greatly reduces the concrete's absorption, but without blocking the concrete's pores and capillaries. The impregnated building material retains very high water-vapor permeability.

Applications

SILRES® BS 290 is suitable for the water-repellent treatment of absorbent, porous mineral building materials such as:

- Aerated concrete
- Sand-lime brick
- Cement fiberboards
- Mineral plasters
- Mineral-based natural and composite stone
- Mineral paints
- Brickwork

Comments

Comprehensive instructions are given in the appropriate material safety data sheets. These are available from our sales subsidiaries or can be printed from WACKER's website www.wacker.com.

PREVENTIVE CONCRETE PROTECTION – THE PERFECT PRODUCT FOR EVERY APPLICATION

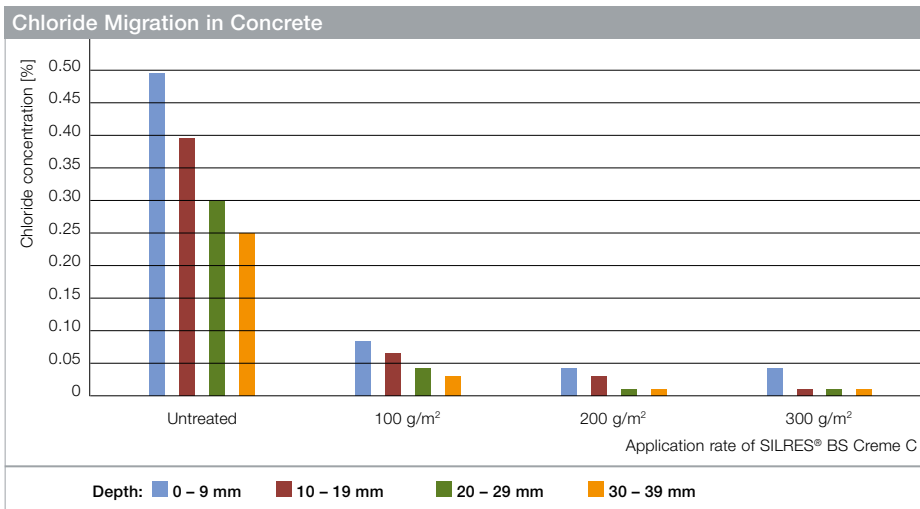

Chloride migration in concrete (strength class C35/45). Untreated specimens and those treated with SILRES® BS Creme C. Specimens conditioned for 10 days in 10% NaCl solution.

Hydrophobic Impregnation Agents – Test Results – DIN EN 1504-2

	Actives	Type	Use	Applications				
				Drying rate coefficient	Absorption ratio	Absorption rate after exposure to alkali	Freeze-thaw salt stress test	Depth of penetration
				DIN EN 13579	DIN EN 13580	DIN EN 13580	DIN EN 13581	DIN EN 14630
				Class I: > 30%	< 7,5%	< 10%	Cycles treated vs. control	Class I: < 10 mm
				Class II: > 10%				Class II: ≥ 10 mm
SILRES® BS Creme C	80%	Silane	Ready to use	Class I	+	+	> 20	Class II
SILRES® BS 1701	> 98%	Silane	Ready to use	Class I	+	+	> 20	Class II
SILRES® BS SMK 2101	100%	Silane/siloxane	Dilute to 25% actives	Class I	+	+	Not tested	Class I

Hydrophobic Impregnation Agents – Test Result

	Actives	Type	Use	Applications				
				Absorption ratio	Absorption rate after exposure to alkali	Freeze-thaw salt stress test	Depth of penetration	
SILRES® BS 290	100%	Silane/siloxane	Dilute to 20% actives	+	+	Not tested	Class I	

CONCRETE PROTECTION FOR CONCRETE ADVANTAGES

WACKER's SILRES® BS high-tech product series offers property developers three definite benefits for protecting concrete buildings and retaining their value:

- Clear advantage in terms of quality due to unique technology
- Impressive cost savings due to unrivaled cost-effectiveness
- Positive public acceptance due to exemplary environmental compatibility

Outstanding Performance

SILRES® BS protects concrete reliably against water and moisture. Positive effects:

Blocks water and consequently

- Blocks salt: Forms a barrier to chlorides from road salt.
- Blocks corrosion: Reinforcement steel does not rust, since the passivation layer remains intact.
- Blocks frost damage: Frost damage is minimized thanks to highly effective water repellency.

Unique Advantages

- Overall costs: Prevention with SILRES® BS instead of costly repair
- Energy consumption: Treatment reduces energy consumption by minimizing maintenance work and the associated site set-up costs.
- Resource conservation: Lower water and energy consumption is kind on the environment.
- Sustainability: Buildings treated with SILRES® BS have an extended lifespan.

Range of Services and Benefits for Customers at a Glance

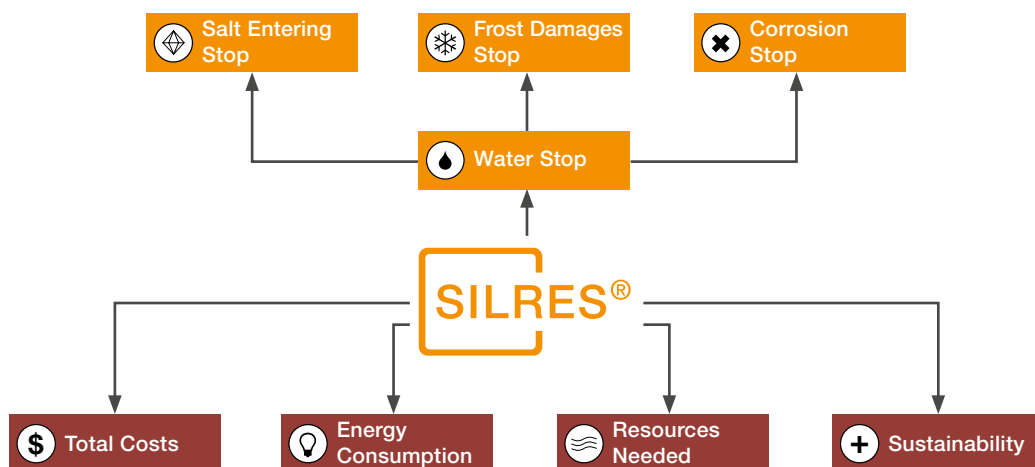

WE BELIEVE CUSTOMER PROXIMITY IS THE KEY TO INNOVATIVE SOLUTIONS

Additional Information

This brochure has shown you what SILRES® BS can achieve as a water-repellent additive for concrete protection. To find out more about SILRES® technical data, please ask for our product data sheets. WACKER can, of course, offer much more for building material protection with silicones. For our complete product range in this area, see our product overview. We will be glad to send you a copy upon request. Or just visit us online at www.wacker.com/silres

Customized Service

Unique challenges require unique solutions. That's why our technical service managers are here for you personally. They understand your production and requirements and know our products and their wide range of benefits. With this background, we can find exactly the solution you need. Just call us. We will be glad to help you, no matter where you are.

WACKER Services

- Technical service
- Inspection and testing of products with and without SILRES® BS
- Selection of appropriate additives and the right dosage

Go for the optimum!

WACKER is one of the world's largest construction-solution providers. Whether used in new construction, refurbishment or renovation, WACKER products meet the most exacting demands by offering the best balance between quality and cost-efficiency. Our comprehensive portfolio – based on a unique combination of the two fully developed technology platforms silicones and polymer chemistry – and our strong service will help you find the optimal solution for your specific application. Talk to us! www.wacker.com/construction



EXPERTISE AND SERVICE NETWORK ON FIVE CONTINENTS



WACKER is one of the world's leading and most research-intensive chemical companies, with total sales of €5.3 billion. Products range from silicones, binders and polymer additives for diverse industrial sectors to bioengineered pharmaceutical actives and hyperpure silicon for semiconductor and solar applications. As a technology leader focusing on sustainability, WACKER promotes products and ideas that offer a high value-added potential to ensure that current and future generations enjoy a better quality of life based on energy efficiency and protection of the climate and environment.

Spanning the globe with 5 business divisions, we offer our customers highly-specialized products and comprehensive service via 25 production sites, 22 technical competence centers, 12 WACKER ACADEMY training centers and 50 sales offices in Europe, North and South America, and Asia – including a presence in China. With a workforce of some 17,000, we see ourselves as a reliable innovation partner that develops trailblazing solutions for, and in collaboration with, our customers. We also help them boost their own success. Our technical centers employ local specialists who assist customers world-

wide in the development of products tailored to regional demands, supporting them during every stage of their complex production processes, if required. WACKER e-solutions are online services provided via our customer portal and as integrated process solutions. Our customers and business partners thus benefit from comprehensive information and reliable service to enable projects and orders to be handled fast, reliably and highly efficiently. Visit us anywhere, anytime around the world at: www.wacker.com

The Wacker logo is presented in a white rectangular box with a black border, featuring the word "WACKER" in a bold, black, sans-serif font.

Wacker Chemie AG
Hanns-Seidel-Platz 4
81737 München, Germany
Tel. +49 89 6279-1741
info@wacker.com

www.wacker.com

www.wacker.com/socialmedia



The data presented in this medium are in accordance with the present state of our knowledge but do not absolve the user from carefully checking all supplies immediately on receipt. We reserve the right to alter product constants within the scope of technical progress or new developments. The recommendations made in this medium should be checked by preliminary trials because of conditions during processing over which we have no control, especially where other companies' raw materials are also being used. The information provided by us does not absolve the user from the obligation of investigating the possibility of infringement of third parties' rights and, if necessary, clarifying the position. Recommendations for use do not constitute a warranty, either express or implied, of the fitness or suitability of the product for a particular purpose.