



## **WACKER – Silicon Competence**

Morgan Stanley Chem Tech Day, London, May 23, 2018

Dr. Fridolin Stary, Senior Vice President Research & Development, Wacker Chemie AG

# Disclaimer

The information contained in this presentation is for background purposes only and is subject to amendment, revision and updating. Certain statements and information contained in this presentation may relate to future expectations and other forward-looking statements that are based on management's current views and assumptions and involve known and unknown risks and uncertainties. In addition to statements which are forward-looking by reason of context, including without limitation, statements referring to risk limitations, operational profitability, financial strength, performance targets, profitable growth opportunities, and risk adequate pricing, other words such as "may, will, should, expects, plans, intends, anticipates, believes, estimates, predicts, or continue", "potential, future, or further", and similar expressions identify forward-looking statements. By their nature, forward-looking statements involve a number of risks, uncertainties and assumptions which could cause actual results or events to differ materially from those expressed or implied by the forward-looking statements. These include, among other factors, changing business or other market conditions and the prospects for growth anticipated by the Company's management. These and other factors could adversely affect the outcome and financial effects of the plans and events described herein. Statements contained in this presentation regarding past trends or activities should not be taken as a representation that such trends or activities will continue in the future. The Company does not undertake any obligation to update or revise any statements contained in this presentation, whether as a result of new information, future events or otherwise. In particular, you should not place undue reliance on forward-looking statements, which speak only as of the date of this presentation.

# WACKER – Our Growth Portfolio

Sales FY 2017 €4.9bn

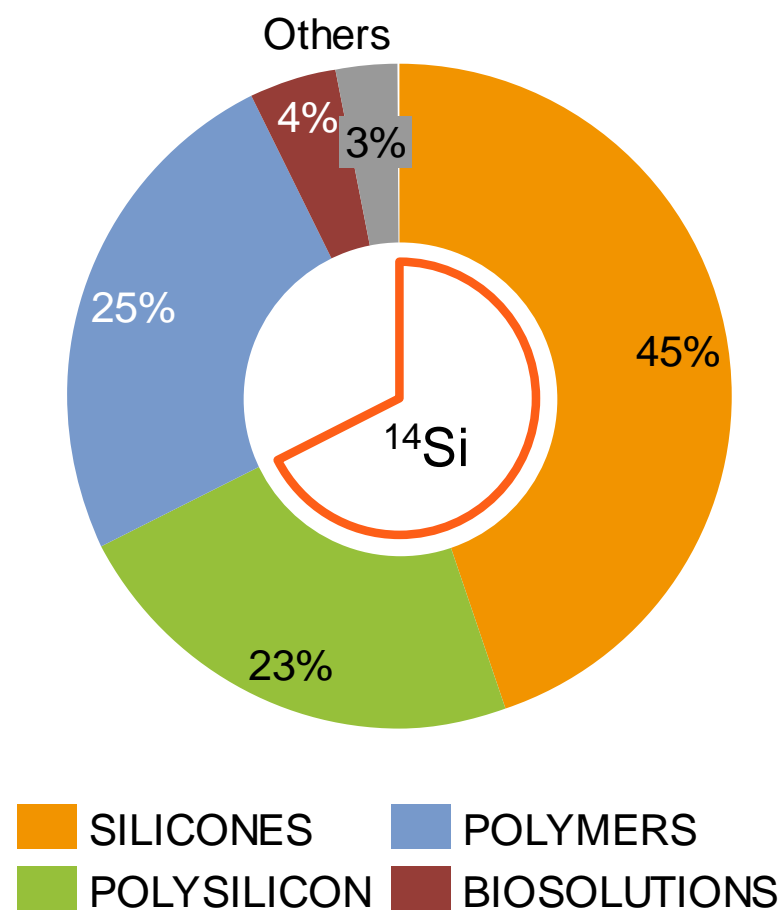

## Our Targets: Growth and Cash

- 1 Extend Leverage Phase
- 2 Continue to Grow Above Chemical Production
- 3 Focus on Sustainability
- 4 Sustain Attractive Margins Through Economic Cycle
- 5 Generate Cash

# **SILICONES**

## **Key Trends and World Class Efficiency Drive Growth**

**Full portfolio  
provider with  
benchmark costs**



**Growth  
with focus on  
specialties**

# SILICONES

## Highest Level of Integration in the Industry

### Open Loop Silicones & Poly Production

#### Standard Processes

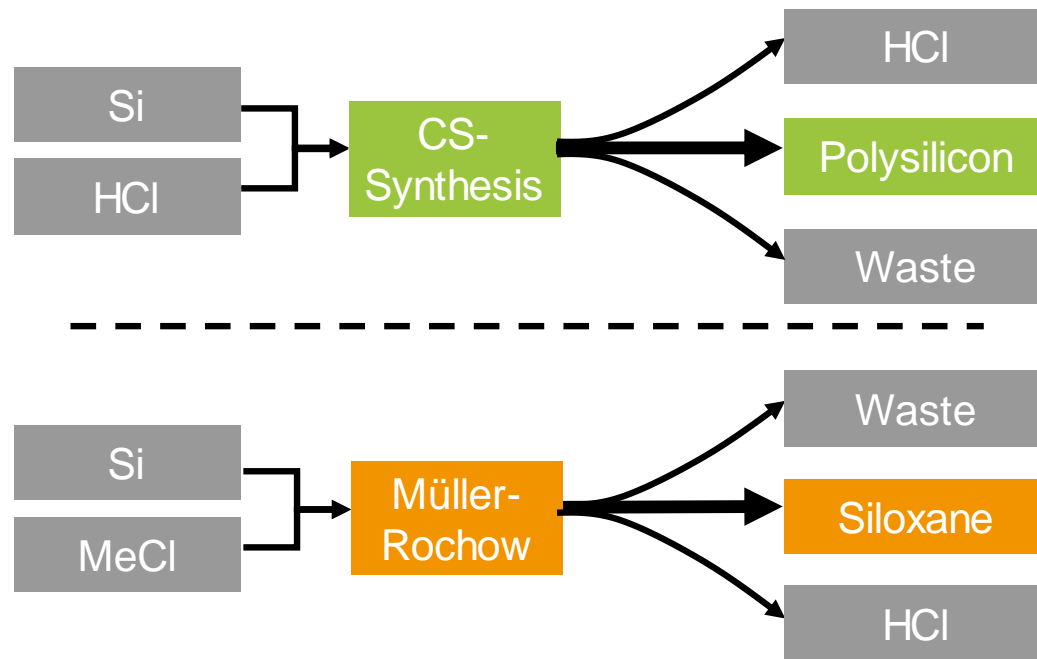

### Unique Silane-Silicone-Silica Loop

#### WACKER

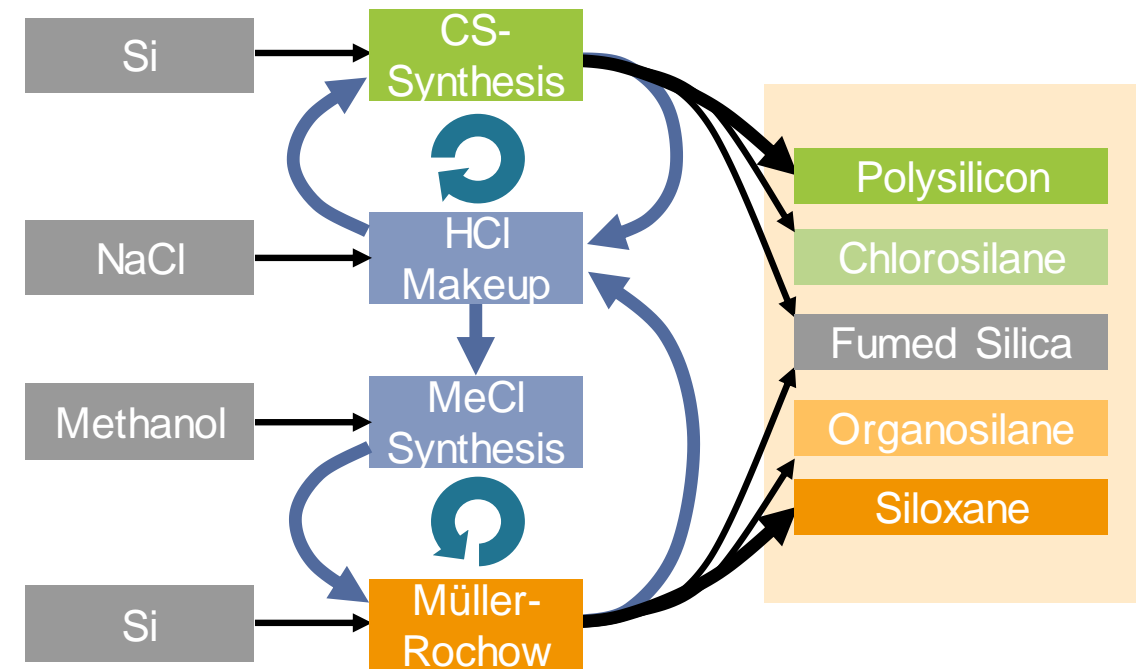

► WACKER Silicon Verbund: Perfectly closed production loops

# SILICONES

## “Verbund” Enables Highly Competitive Cost Position

### “WACKER Silicon Verbund”

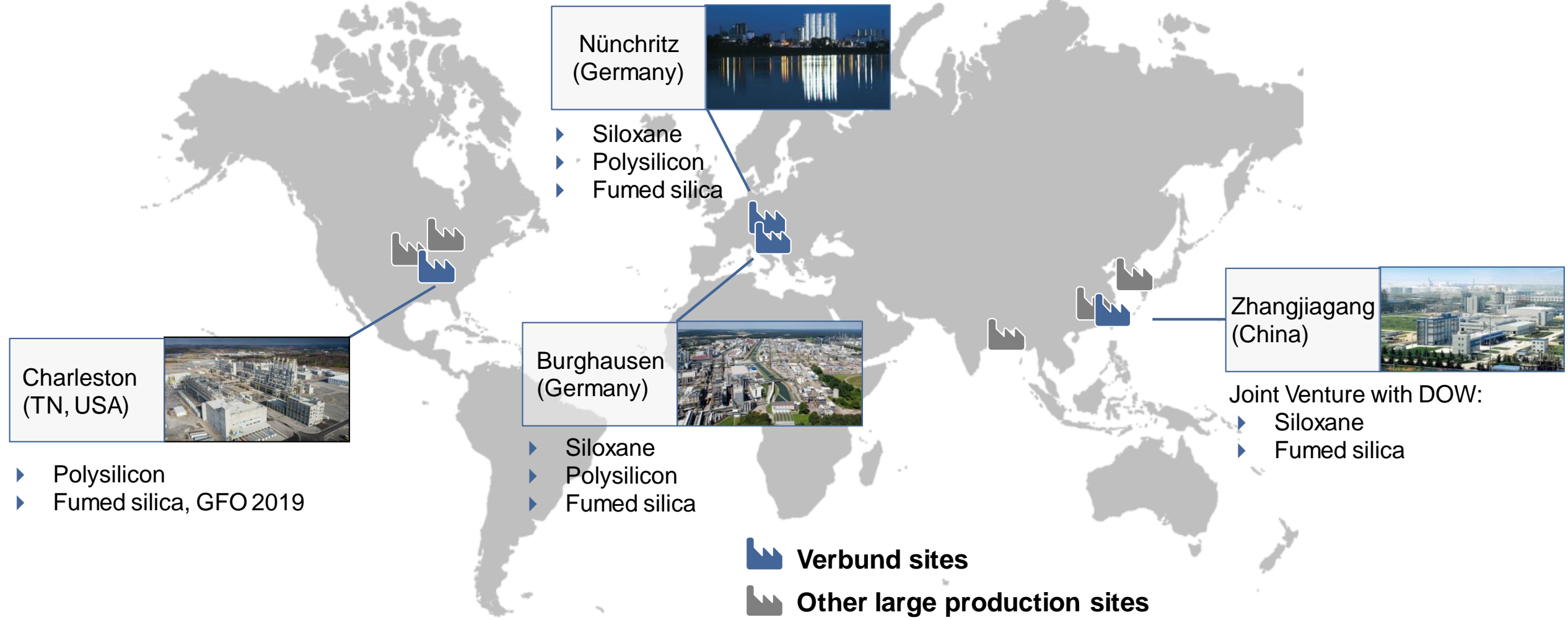

# SILICONES

## Operational Excellence is Key

### Siloxane

Index 2012 = 100%

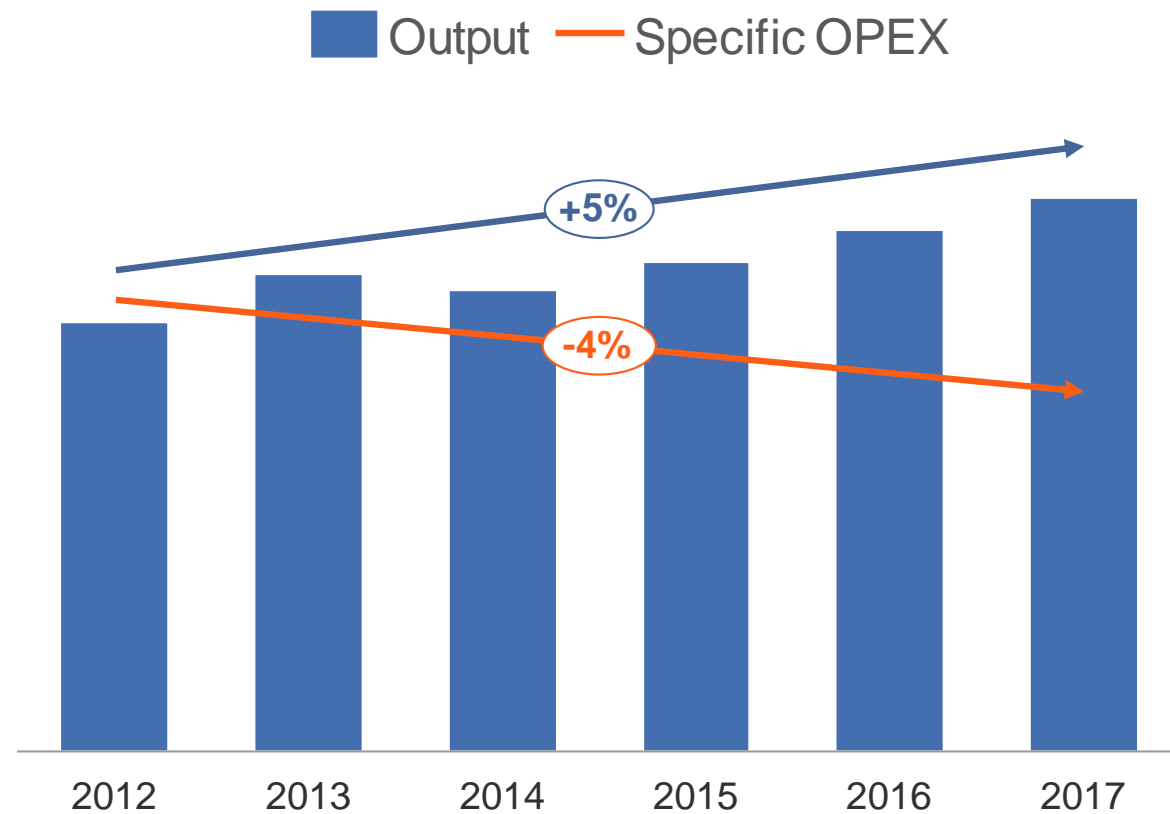

### Fumed silica

Index 2012 = 100%

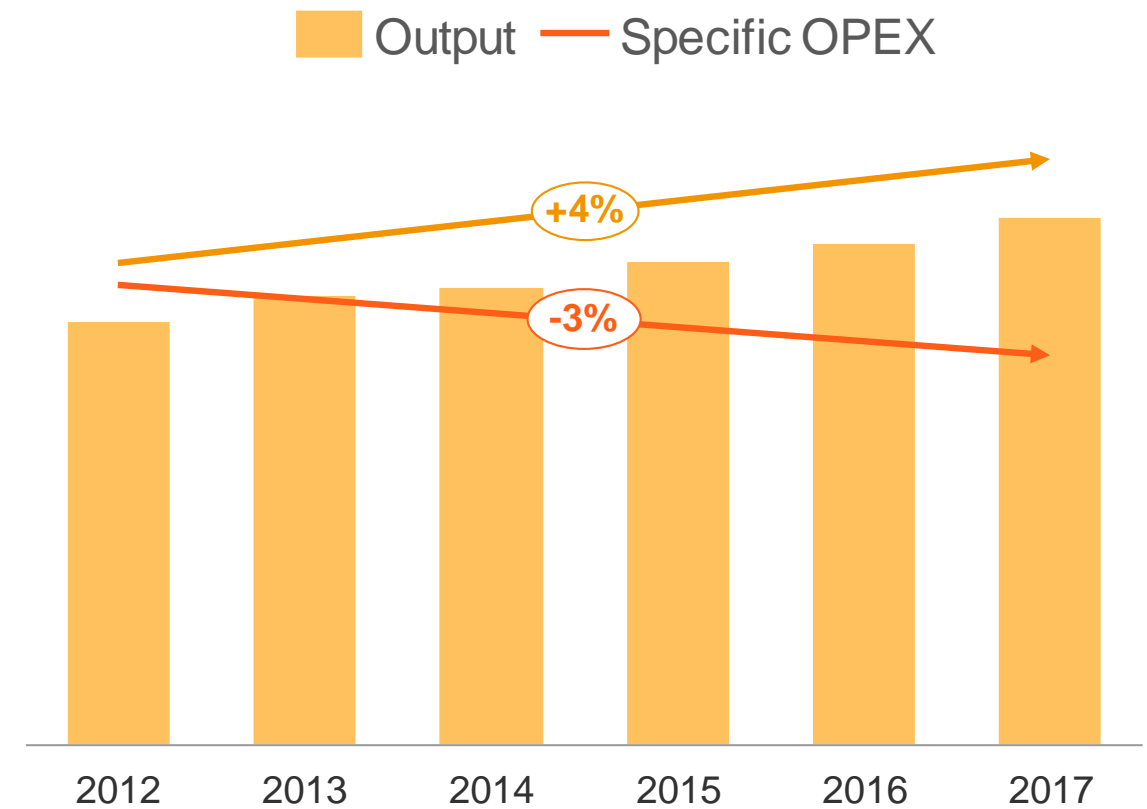







# SILICONES

## Silicones Create Value in Many Industries

Market structure by application

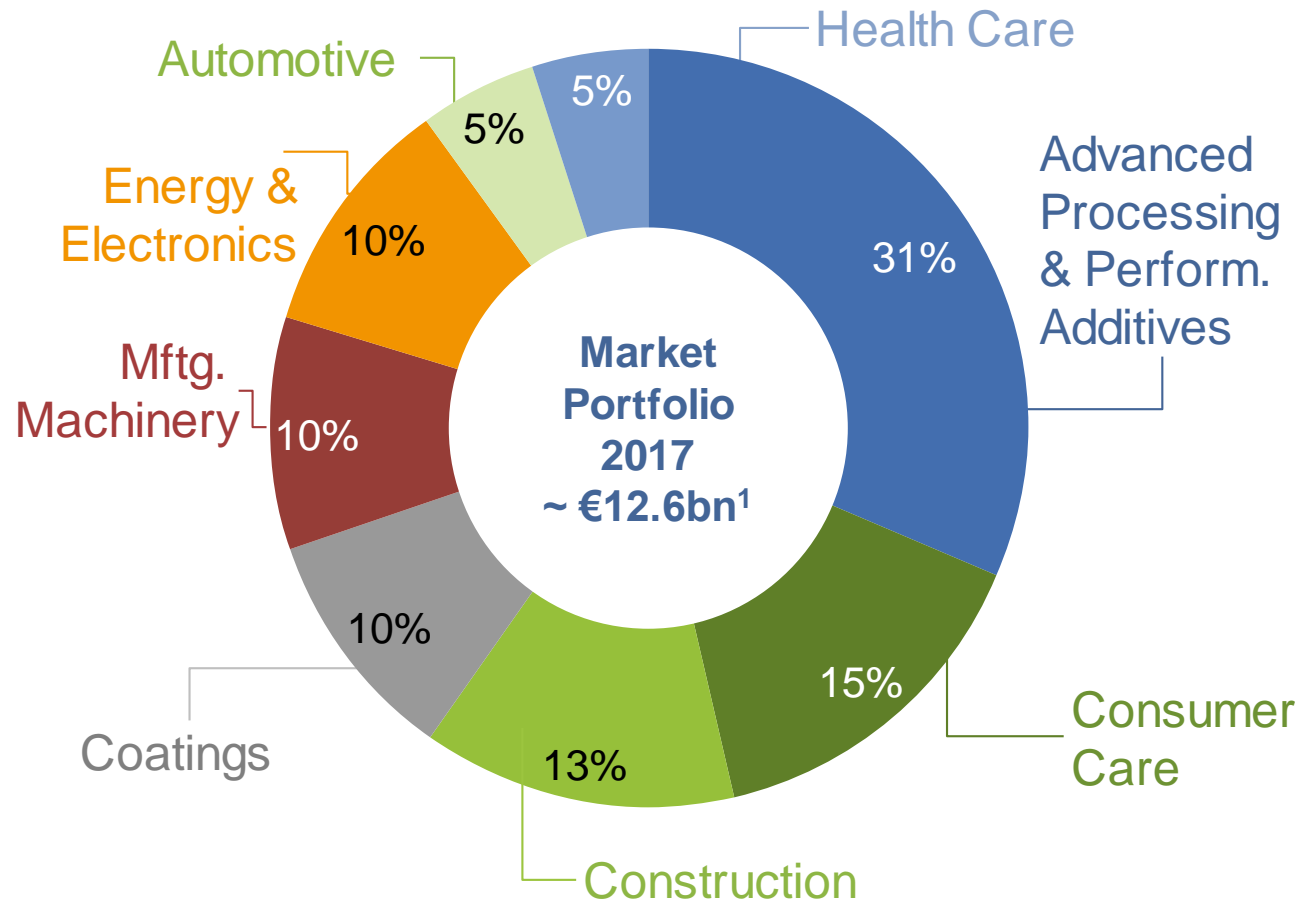

Market volume/shares (€bn, %)

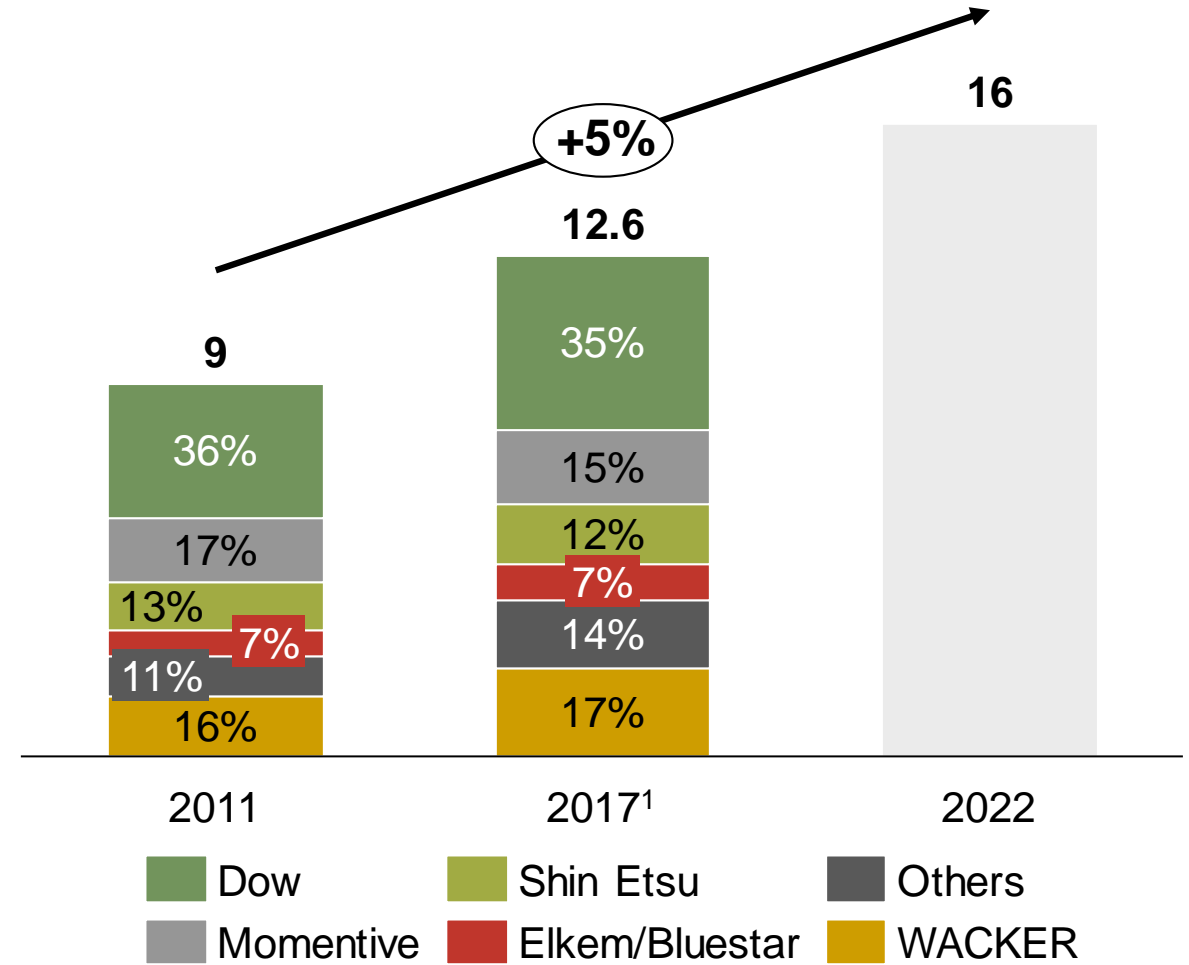

<sup>1</sup> preliminary figures, Source: Freedonia 2017, Company Reports, WACKER Estimate

# SILICONES

## Key Trends Drive SILICONES' Growth



Renewable Energy / E-mobility



Communication



Urbanization



Standard of Living

## Innovation Power Determines Our Market Position

### Product innovation

#### Substitution Drivers

Process efficiency &  
unique material properties



WACKER SiGel®  
for optical bonding

#### New Markets

High performance products  
for future growth markets



ELASTOSIL® R  
for EVs



# SILICONES

## Transformation Need for Automotive Applications

Silicones in automotive: €600m market value in 2017

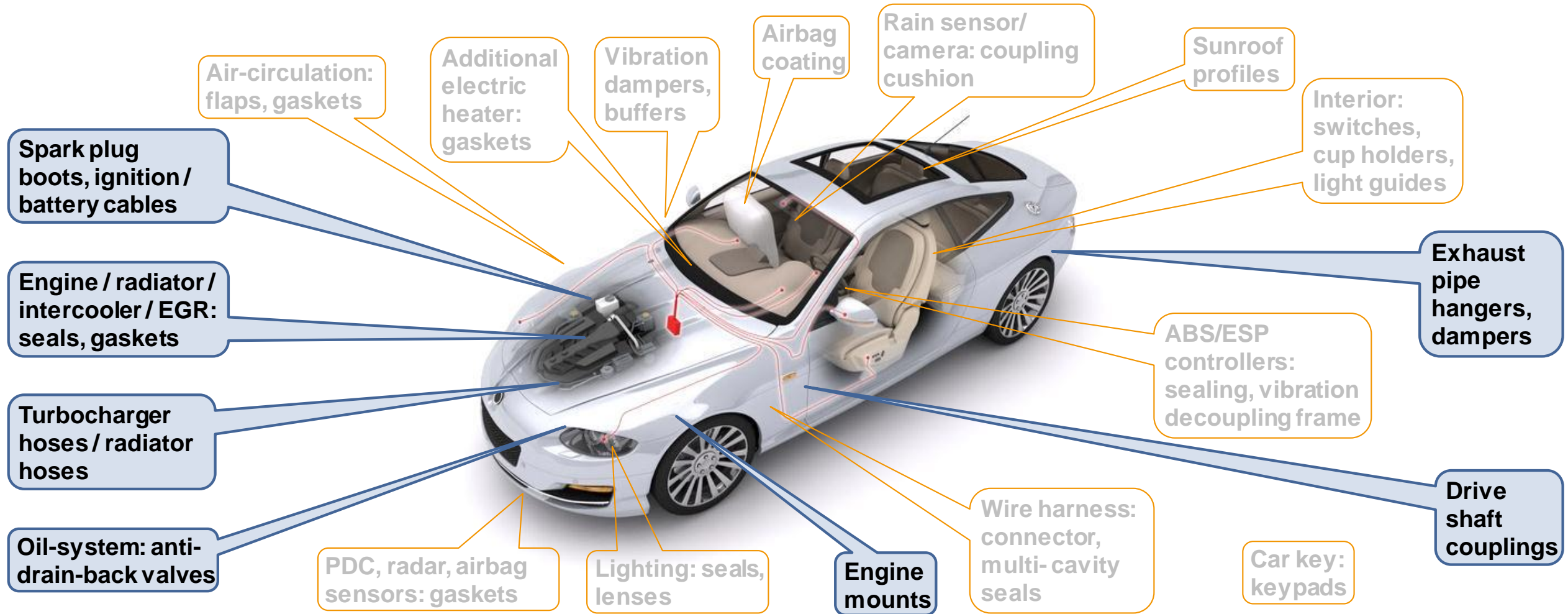

## EVs: Need for New Materials with New Profile of Requirements

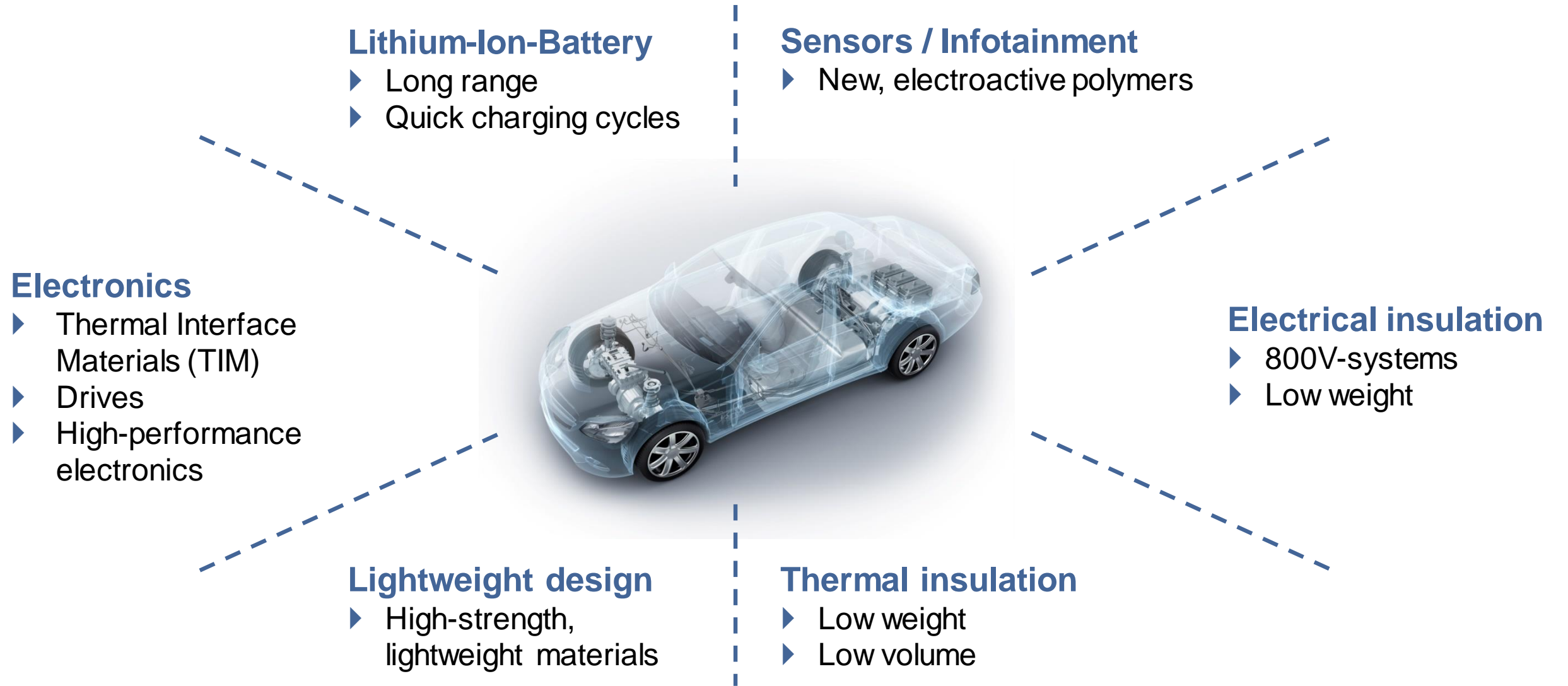

# SILICONES

## Thermal Management of EV-Cell Packs Through Silicone TIMs

### Example: Thermal interface materials (TIMs)

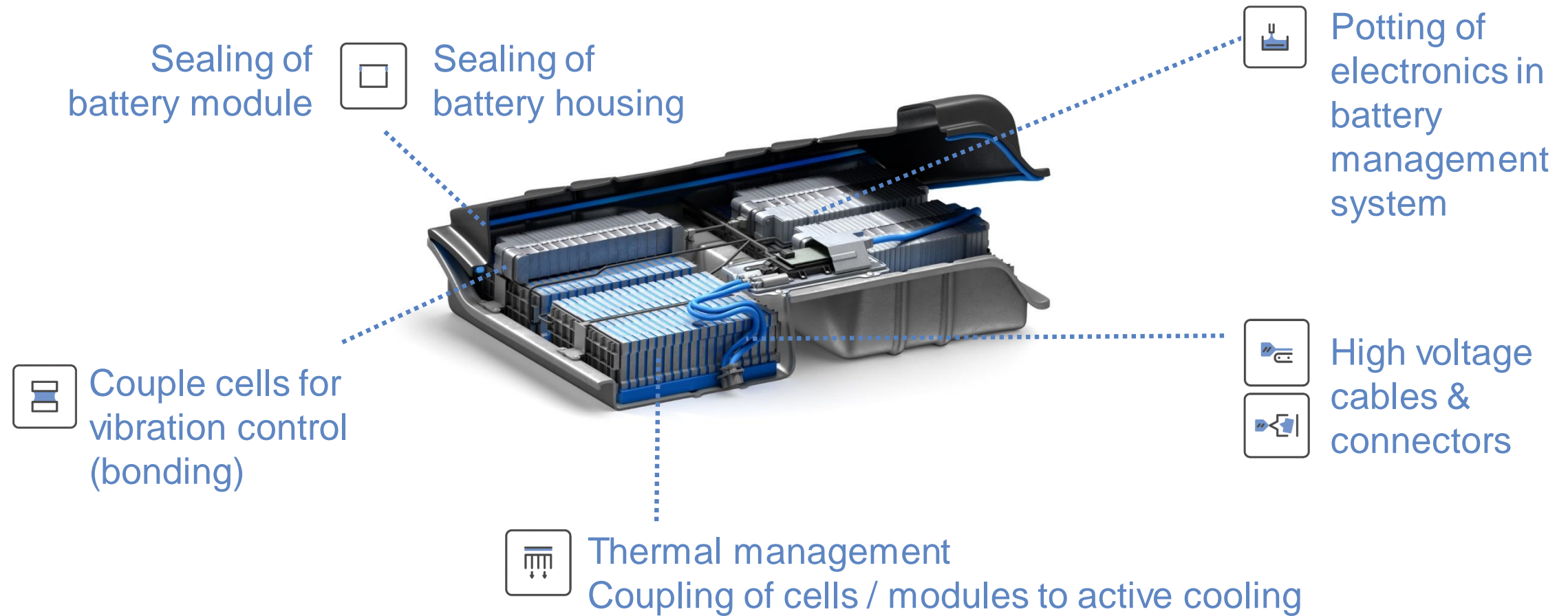



# SILICONES

## Specialties Meet Increasing Performance Requirements

### Coatings



### Healthcare

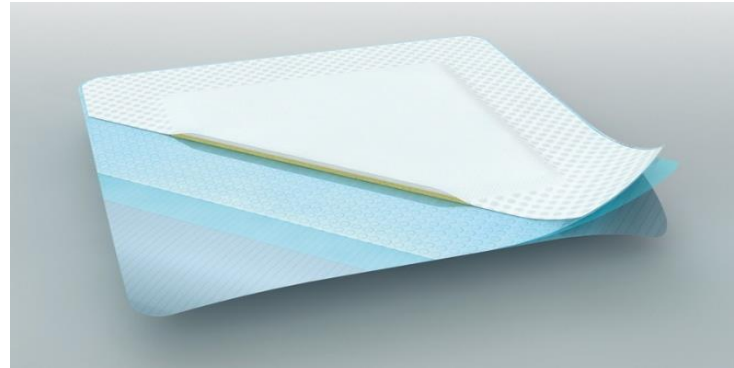

### Energy Transmission



# SILICONES

## A Business with High Profitable Growth Potential



### WACKER SILICONES

- ▶ Global presence
- ▶ Full portfolio provider
- ▶ Leading technology, cost and environmental position
- ▶ Innovation power for emerging new technological needs



## WACKER – Silicon Competence

Morgan Stanley Chem Tech Day, London, May 23, 2018

Dr. Fridolin Stary, Senior Vice President Research & Development, Wacker Chemie AG